

Wireless Controllers and Receivers

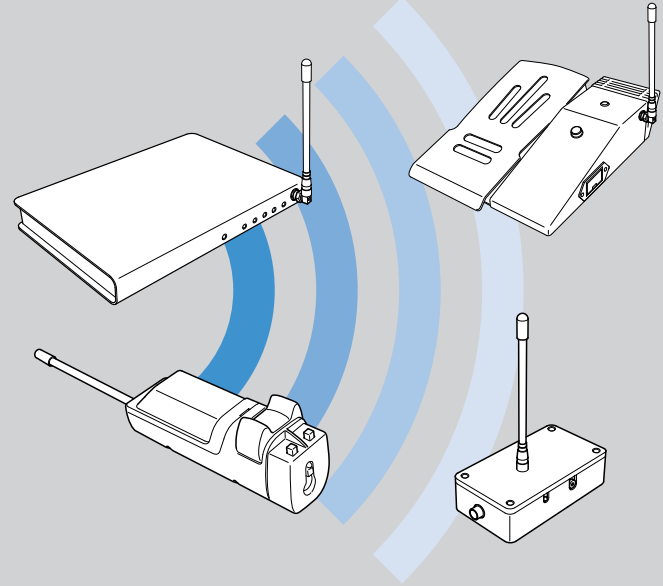

Part Nos. WSC-REC/-A
WSC-RAT/-A
WFC/-A
SCB-W/-A
WSC/WSC-A
WFC-PKG-US
WFC-PKG-ROW

Copyright © 2015

All rights reserved.

Original Instructions: English

All rights reserved throughout the world. No part of this document may be stored in a retrieval system, transmitted, copied or reproduced in any way, including, but not limited to, photocopy, photograph, magnetic or other record without the prior agreement and permission in writing of the Vitec Group plc.

Disclaimer

The information contained in this manual is believed to be correct at the time of printing. Vitec Videocom Ltd reserves the right to make changes to the information or specifications without obligation to notify any person of such revision or changes. Changes will be incorporated in new versions of the publication.

We are making every effort to ensure that our manuals are updated on a regular basis to reflect changes to product specifications and features. Should this manual not contain information on the core functionality of your product, please let us know. You may be able to access the latest revision of this manual from our website.

Vitec Videocom Ltd reserves the right to make changes to product design and functionality without notification.

Trademarks

All product trademarks and registered trademarks are the property of The Vitec Group Plc.

All other trademarks and registered trademarks are the property of their respective companies.

Published by:

Vitec Videocom Ltd
Supports Technical Publications Department
Western Way, Bury St Edmunds
Suffolk IP33 3TB
United Kingdom
Email: technical.publications@vitecgroup.com

Safety	2	Routine Maintenance	24
About this Guide	3	Cleaning	24
Components and Connections	4	Changing the Fuse (Wireless Smart Combiner Box)	24
Key Components	4	Troubleshooting	25
Box Contents	7	Re-initialising the Hand or Foot Controller	26
Tools Required	8	Reliable Wireless Operation	26
Installation	9	Technical Specification	27
Fitting the Antenna	9	General Notices	29
Fitting the Battery - Hand Controller	10		
Fitting the Battery - Foot Controller	11		
Receiver Unit or Wireless Smart Combiner Box Location	12		
Control Net Connections	12		
Serial Connections	13		
Power Connections	13		
Control System Connections - Single Controllers	14		
Control System Connections - Multiple Controllers	15		
Powering Up	16		
Configuration	17		
Channel Frequency Selection	17		
Receiver Indication	19		
Operation	20		
Using the Hand Controller	20		
Using the Foot Controller	22		
Priority Control	23		
Maintenance	24		

Important information on the safe installation and operation of this product. Read this information before operating the product. For your personal safety, read these instructions. Do not operate the product if you do not understand how to use it safely. Save these instructions for future reference.

Warning Symbols Used in these Instructions

Safety cautions are included in these instructions. These safety instructions must be followed to avoid possible personal injury and avoid possible damage to the product.



WARNING!

Where there is a risk of personal injury or injury to others, comments appear supported by the warning triangle symbol. Where there is a risk of damage to the product, associated equipment, process or surroundings, comments appear supported by the word 'Caution'.



ELECTRIC SHOCK

Where there is a risk of electric shock, comments appear supported by the hazardous voltage warning triangle.

Intended Use

The wireless controllers and receivers have been designed to provide prompter function operational control as part of a high quality teleprompting facility for television broadcasting.

They are intended for use by television presenters and camera operators, installed within a television studio environment, or on outside broadcasts (OB) when protected from weather by a suitable waterproof cover.

Electrical Connection



WARNING! Risk of electric shock. Always check cables for signs of damage. Damaged cables can cause personal injury and/or damage the equipment.



CAUTION! The products must be connected to a power supply of the same voltage (V) and current (A) as indicated on the products. Refer to the technical specifications for the products.



CAUTION! Only use the power cable specified for the products and certified for the country of use.



CAUTION! Using alternative power sources will invalidate the system EMC liability.



CAUTION! Only use the battery type specified for the products.

Basic Electrical Insulation (Class 1 equipment)



WARNING! This product is Class 1 equipment. For safe operation this equipment must be connected to a power supply that has a protective earth connection (US: ground).

Water, Moisture and Dust



WARNING! Protect the product from water, moisture and dust. The presence of electricity near water can be dangerous.



WARNING! When using this product outside, protect from rain using a suitable waterproof cover.

Mounting and Installation



WARNING! Always ensure that all power and auxiliary communications cables are routed so that they do not present any danger to personnel. Take care when routing cables in areas where robotic equipment is in use.

Ventilation



WARNING! Slots and openings are intended for ventilation purposes to ensure reliable operation of the product, and protect it from overheating. Do not block or cover any slots and openings.

Operating Environment



CAUTION! The product should not be used outside the operating temperature limits. Refer to the product technical specifications for the operating limits for the product.

Cleaning



WARNING! Risk of electric shock. Always disconnect and isolate the product from the power supply before cleaning.



CAUTION! Do not use solvent or oil-based cleaners, abrasives or wire brushes.

Maintenance



WARNING! Servicing or repair of this product must only be performed by qualified and trained electrical engineers.



WARNING! The fitting of non-approved parts and accessories, or the carrying out of non-approved alterations or servicing can be dangerous and could affect the safety of the product. It may also invalidate the terms and conditions of the product warranty.

About this Guide

This guide describes the installation and operation of the wireless controllers and receivers as part of a full prompting system, using the range of compatible equipment and connecting cables available for various configurations.

The range of products covered in this guide consists of the following:

Part No.	Description
WSC-RAT	Hand control transmitter for wireless scroll control, 433 MHz
WSC-RAT-A	Hand control transmitter for wireless scroll control, 900 MHz
WFC	Wireless magno foot control, 433 MHz
WFC-A	Wireless magno foot control, 900 MHz
WSC-REC	Wireless receiver unit, 433 MHz
WSC-REC-A	Wireless receiver unit, 900 MHz
SCB-W	Wireless smart combiner box, 433 MHz
SCB-W-A	Wireless smart combiner box, 900 MHz

900 MHz versions are for use in the US only, and 433MHz versions in the rest of the world.



CAUTION! The wireless transmitter and receiver products are unique to each region and **MUST NOT**, under any circumstances, be used in an unauthorised area.

Components and Connections

Key Components

Hand Controller

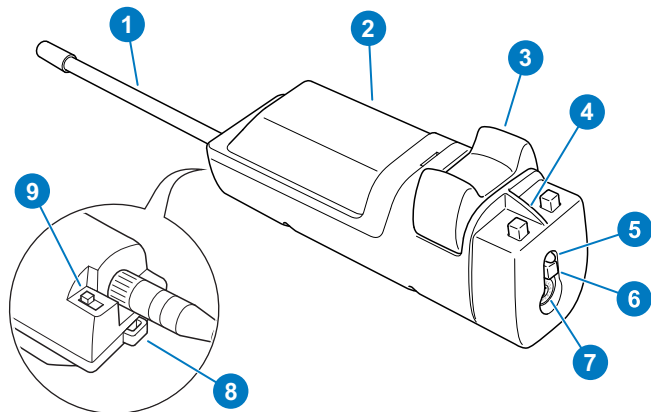

- | | |
|---|---------------------------|
| 1 | Antenna |
| 2 | Battery compartment |
| 3 | Scroll thumb control |
| 4 | Next/previous buttons |
| 5 | Low battery indicator LED |
| 6 | Function button |
| 7 | Channel selector |
| 8 | Lanyard strap loop |
| 9 | Power on/off switch |

Foot Controller

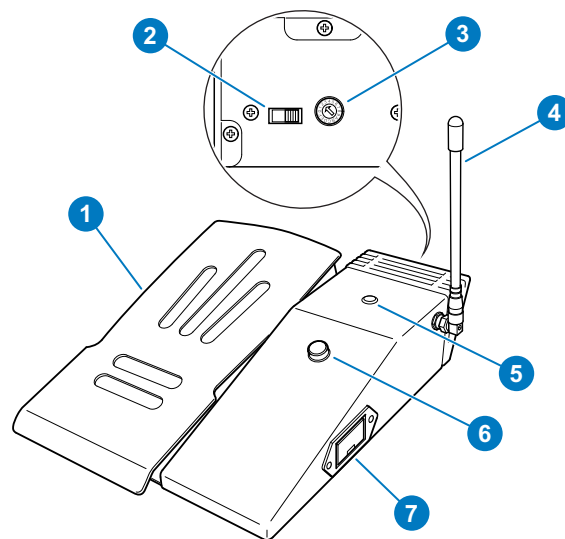

- | | |
|---|-------------------------|
| 1 | Scroll speed foot pedal |
| 2 | Power on/off switch |
| 3 | Channel selector |
| 4 | Antenna |
| 5 | Direction indicator LED |
| 6 | Reverse control button |
| 7 | Battery compartment |

Receiver Unit - Front View

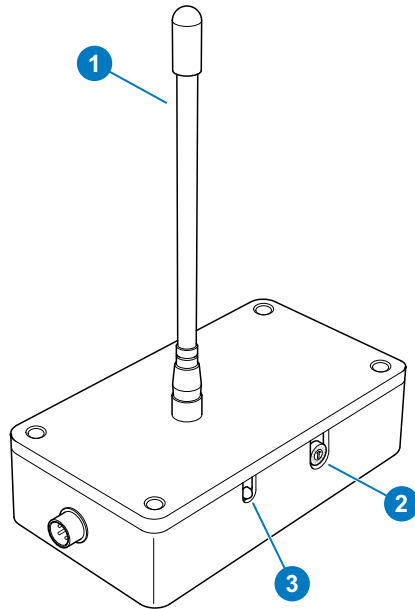

- | | |
|---|--------------------------------|
| 1 | Antenna |
| 2 | Channel selector rotary switch |
| 3 | Receiver indicator LED |

Receiver Unit - Rear View

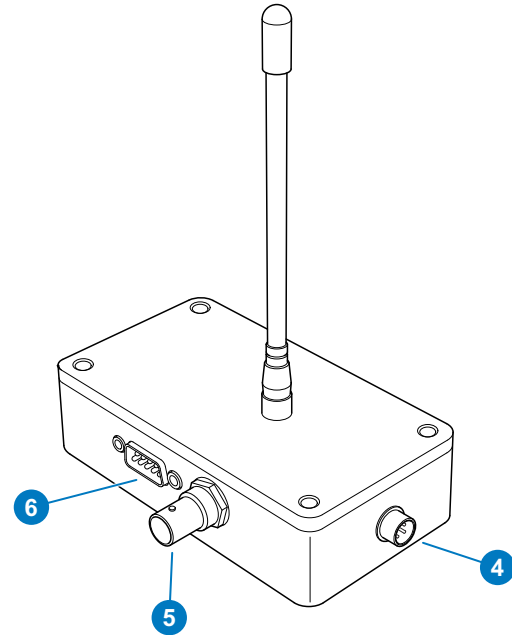

- | | |
|---|-----------------------|
| 4 | Power connector |
| 5 | Control Net connector |
| 6 | Serial connector |

Components and Connections

Wireless Smart Combiner Box - Front View

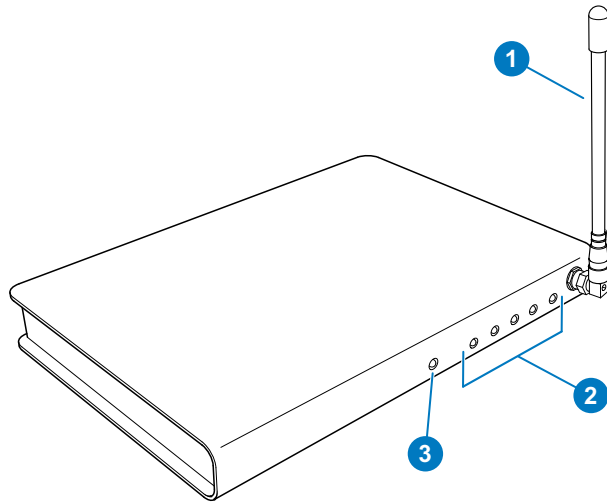

1	Antenna
2	Channel indicator LEDs
3	Power indicator LED

Wireless Smart Combiner Box - Rear View

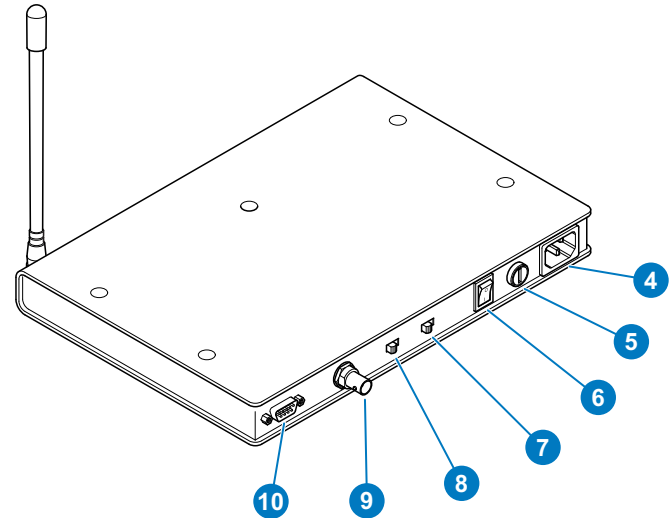

4	AC power in socket
5	Fuse holder
6	Power switch
7	Bandwidth selection switch (currently not in use)
8	Frequency range selection switch
9	Control Net connector
10	Serial connector

Box Contents

Hand Controller

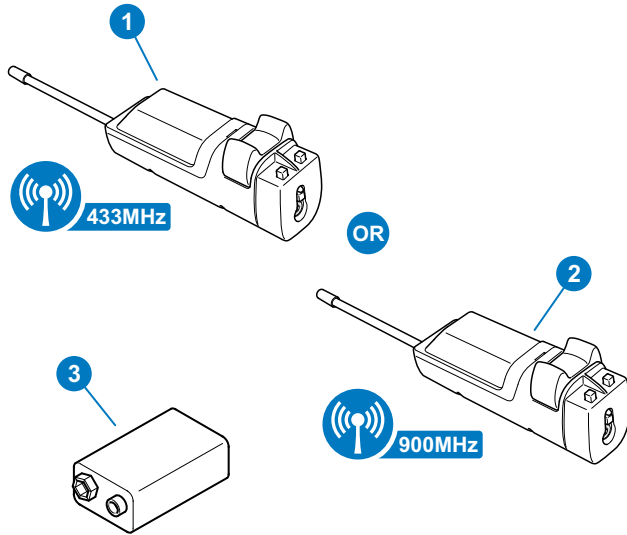

No.	Part	Description
1	WSC-RAT	Hand control transmitter, 433 MHz
2	WSC-RAT-A	Hand control transmitter, 900 MHz (U.S. only)
3		9 Volt PP3 alkaline battery

Foot Controller

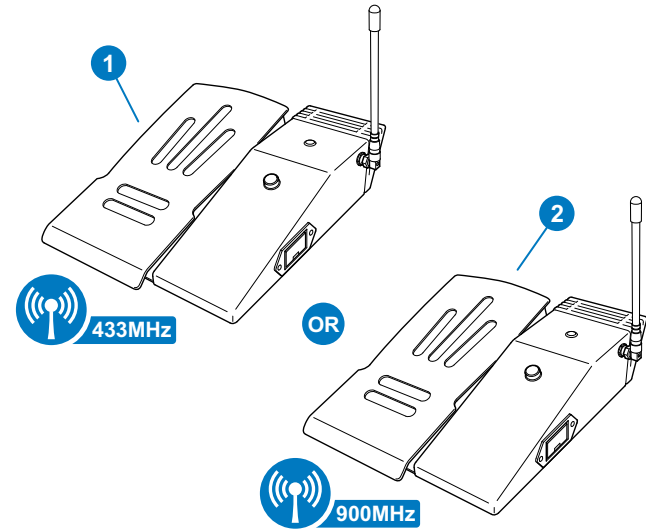

No.	Part	Description
1	WFC	Foot controller, 433 MHz
2	WFC-A	Foot controller, 900 MHz (U.S. only)

Components and Connections

Receiver Unit

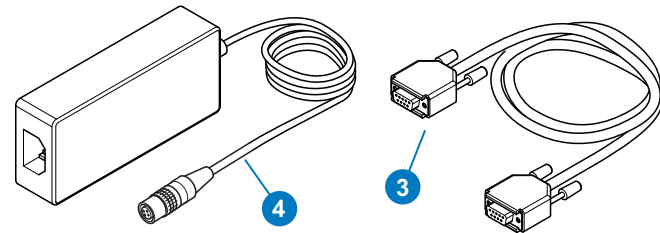
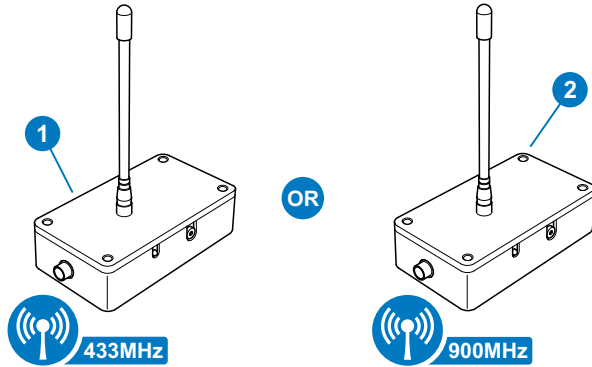

No.	Part	Description
1	WSC-REC	Wireless receiver unit, 433 MHz
2	WSC-REC-A	Wireless receiver unit, 900 MHz
3	SRL-C	9 pin to 9 pin serial cable
4	PSU-HR	Hirose DC power supply unit

Wireless Smart Combiner Box

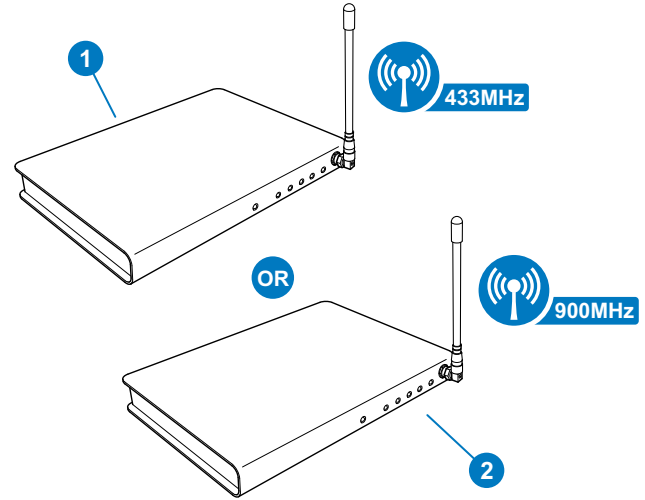

No.	Part	Description
1	SCB-W	Wireless smart combiner box, 433 MHz
2	SCB-W-A	Wireless smart combiner box, 900 MHz

Tools Required

Potentiometer
adjuster or small flat
blade screwdriver.

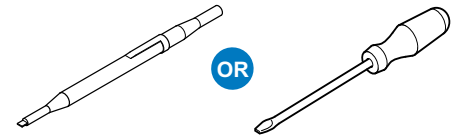

Fitting the Antenna

Hand Controller

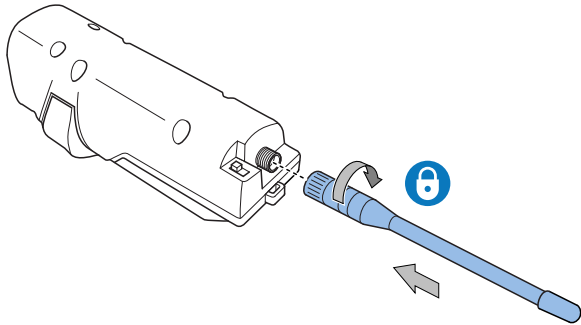

Foot Controller

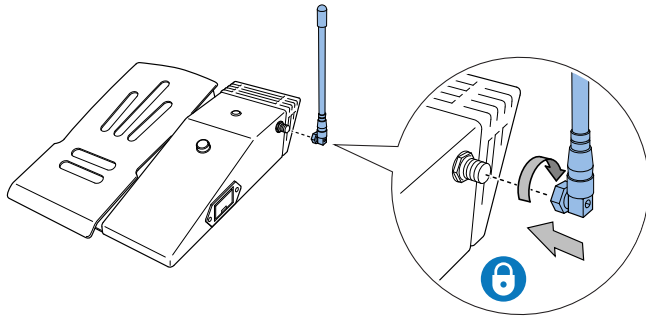

Receiver Unit

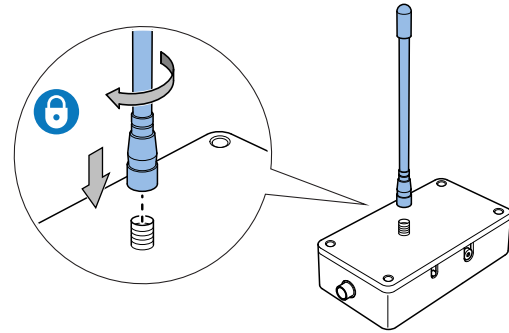

Wireless Smart Combiner Box

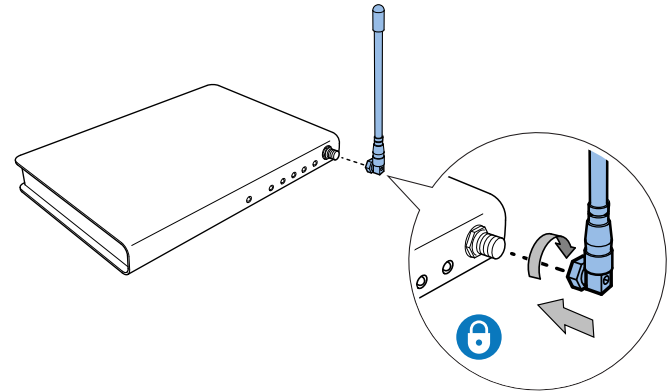

Installation

Fitting the Battery - Hand Controller

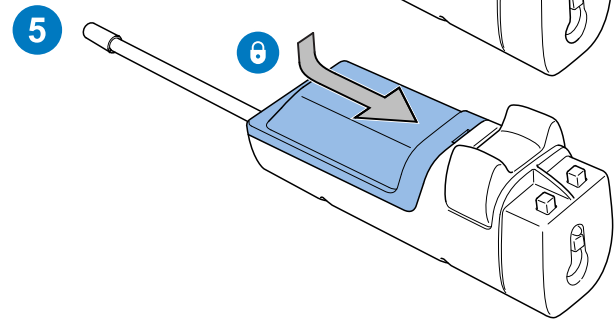
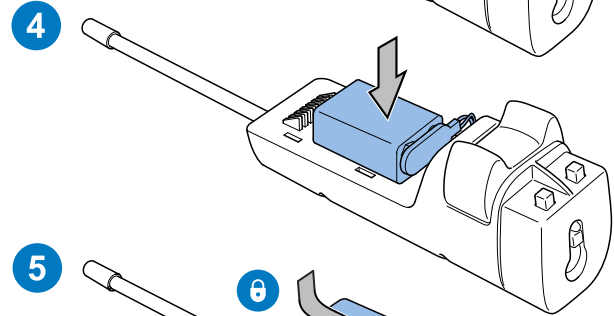
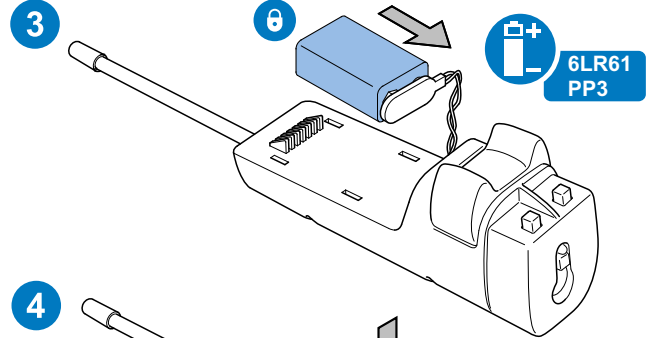
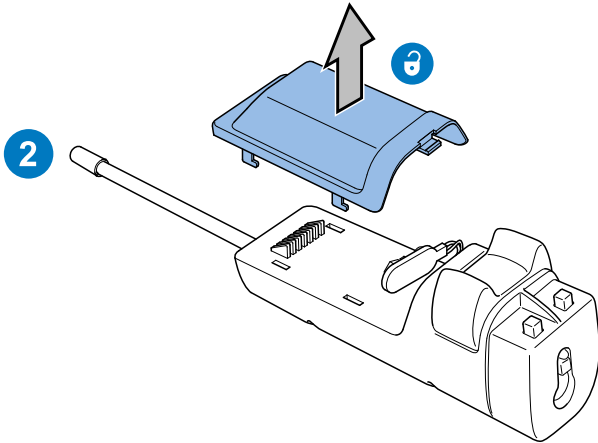
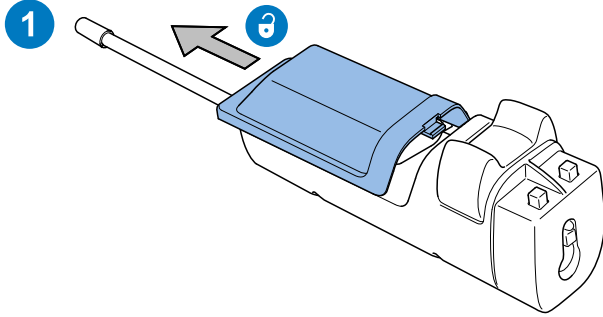

Fitting the Battery - Foot Controller

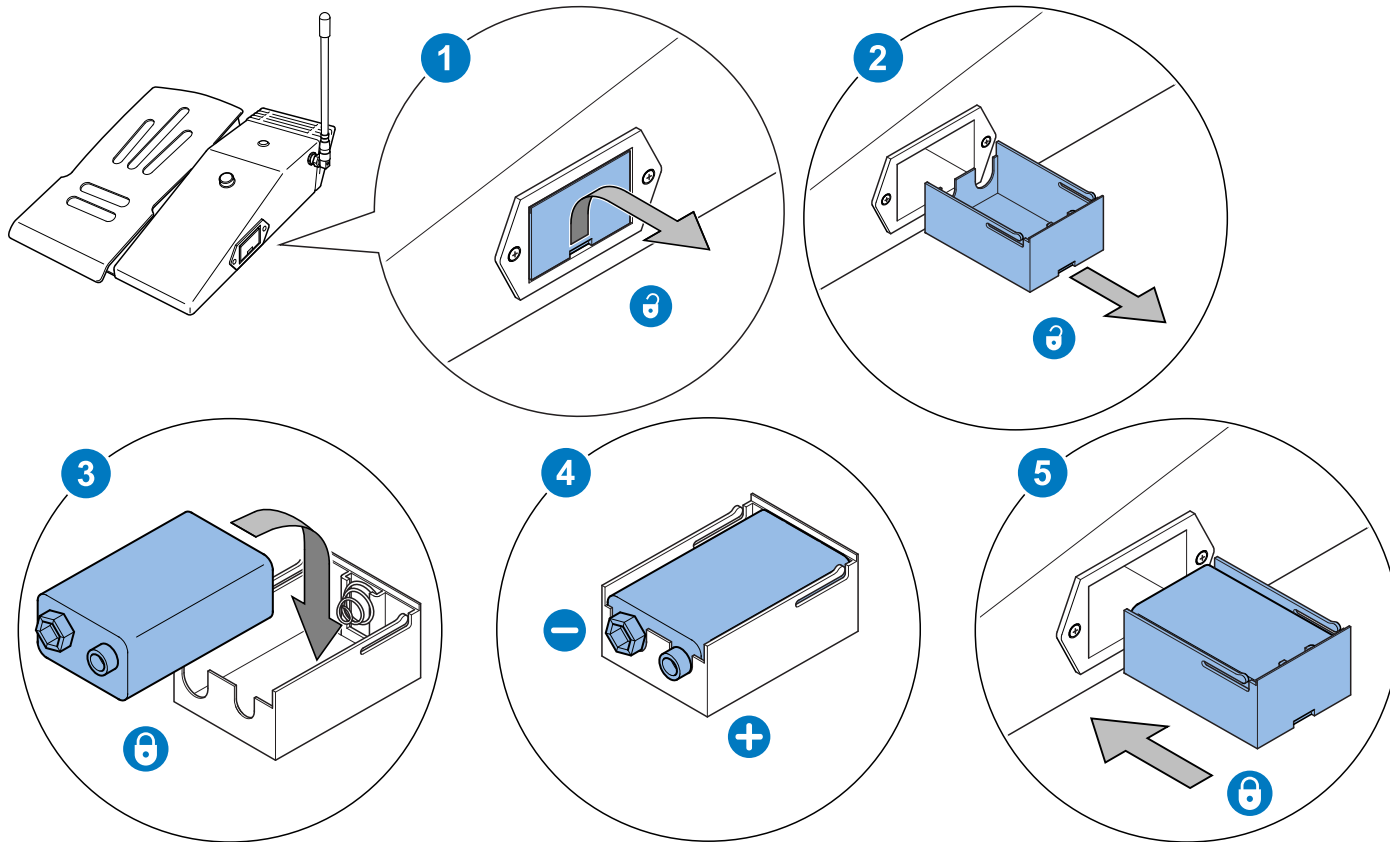

Installation

Receiver Unit or Wireless Smart Combiner Box Location

Special consideration should be given when choosing a location to install the receiver unit or smart combiner box.

- Using Control Net connections, the products can be up to 300 metres away from the control system. If serial connections are used, the range is significantly reduced to 18 metres.

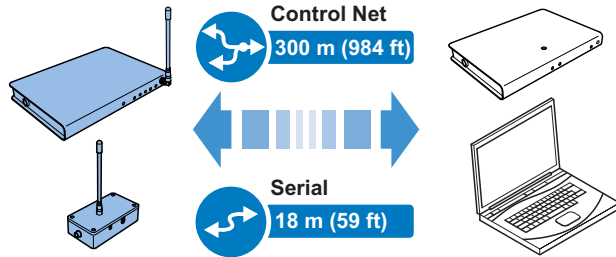

- For radio reception, the products must be operated within the distances shown, line of sight from the location of receivers.

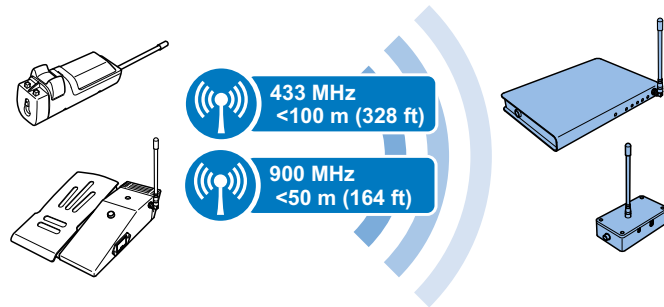

Control Net Connections



Control Net connections should always be made with screened 75 Ω coaxial cable. The cable screen must be connected to earth (ground) at both ends.

Receiver Unit

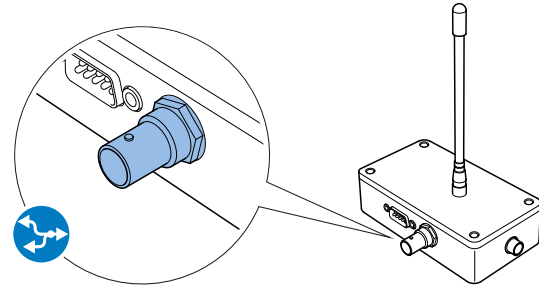

Wireless Smart Combiner Box

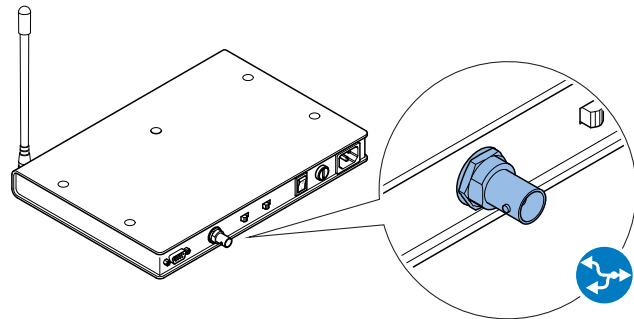

Serial Connections

The receiver unit can be connected directly to an Xbox Ultra unit using a serial cable, which provides both power and data. Alternatively, the receiver unit can be externally powered from a 12 volt power supply, and connected either to the Control Net input of the Xbox Ultra or an input on a wired Smart Combiner Unit.

Receiver Unit

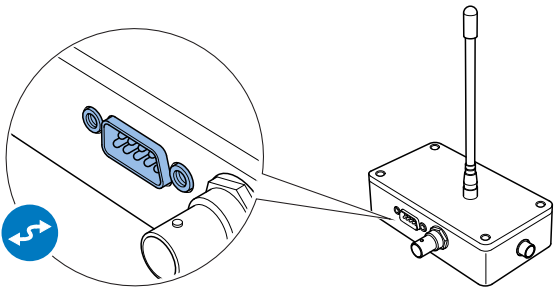

Smart Combiner Box

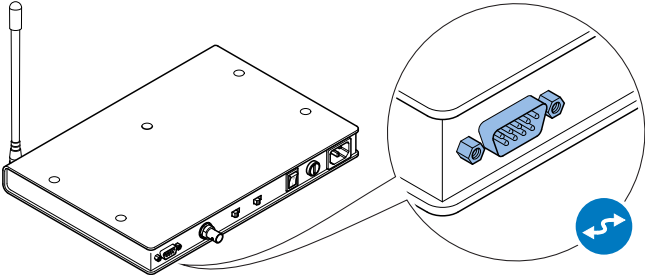

Power Connections

Receiver Unit

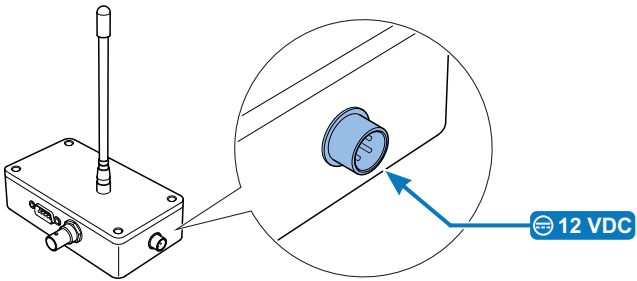

Wireless Smart Combiner Box

⚠ WARNING! This product is Class 1 equipment. For safe operation this equipment must be connected to a power supply that has a protective earth connection (US: ground). Ensure that an IEC 3-core AC supply cable is used.

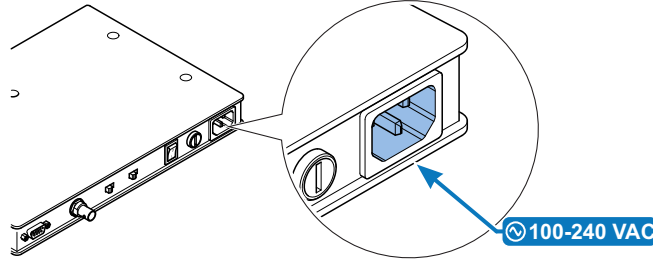

Installation

Control System Connections - Single Controllers

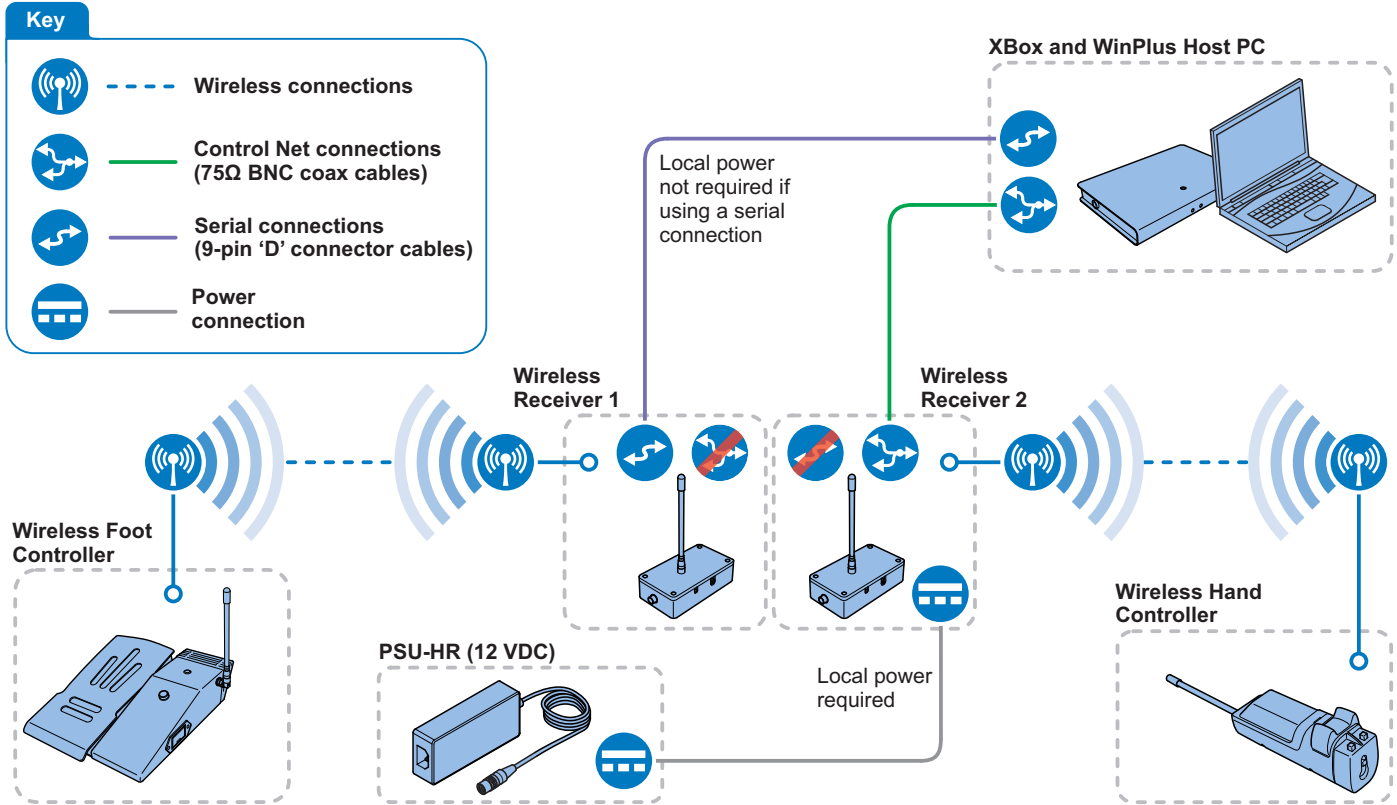

Control System Connections - Multiple Controllers

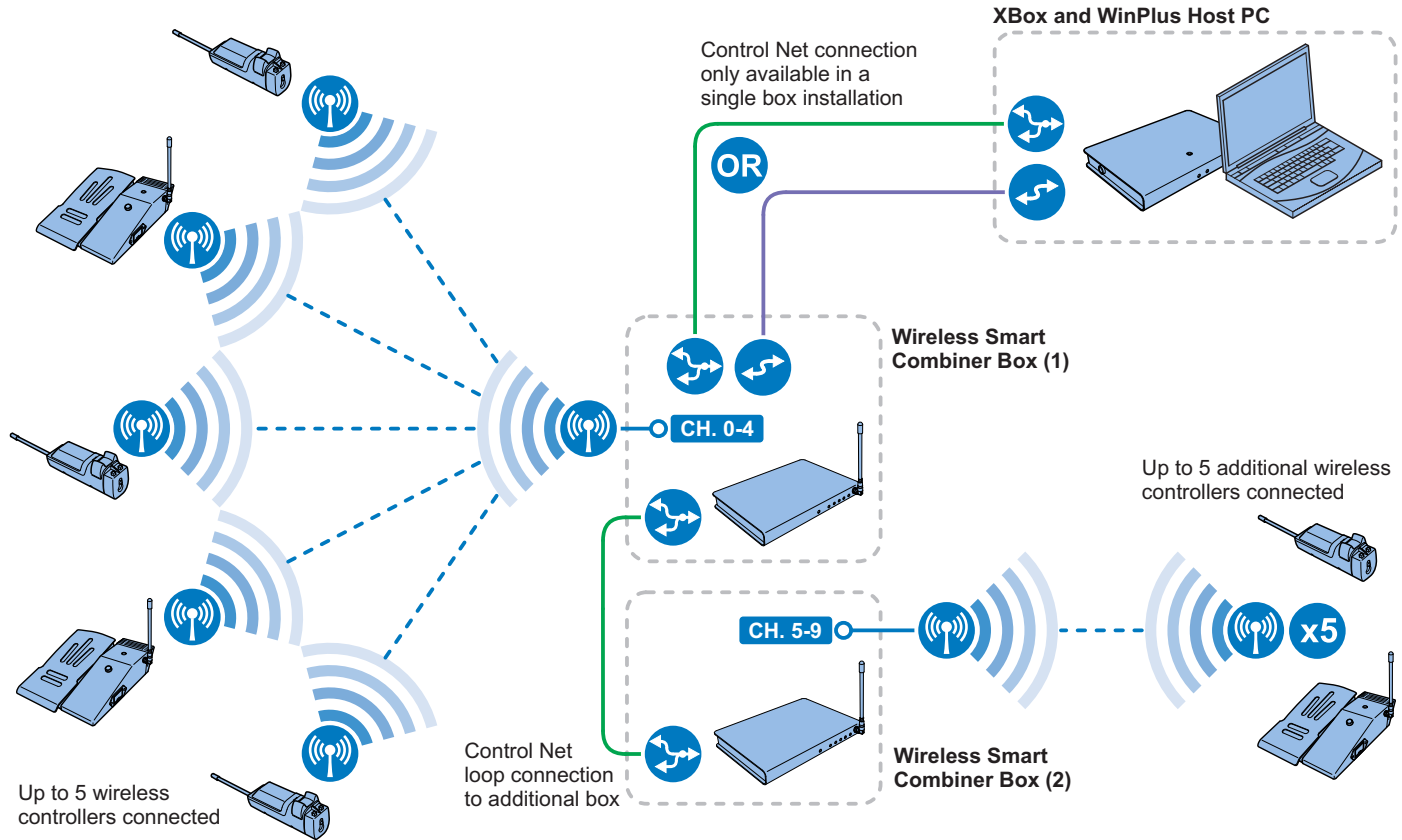

Installation

Powering Up

Hand Controller

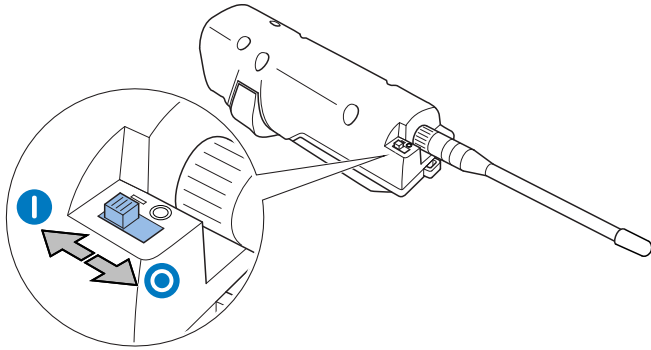

Foot Controller

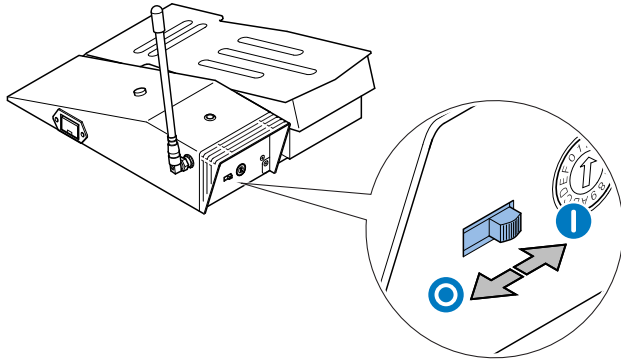

Receiver Unit

The receiver unit does not have a power switch, and is powered up constantly when a live power supply is connected. For more information, see the section **Power Connections** on page 13.

Wireless Smart Combiner Box

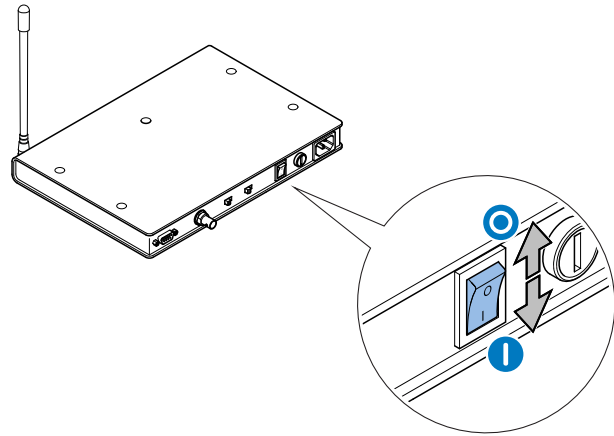

Channel Frequency Selection

For the wireless system to function, the channels used by each device (frequencies) must be configured correctly.



Up to 14 channels can be used in a single installation



To avoid conflict, the wireless controllers must be set to different channels



An individual receiver unit must be set to the same channel as the controller device



14 channels (0 to D) are available for selection on the hand and foot controllers, and the receiver unit



Two groups of five channels (0 to 4 and 5 to 9) can be received by a wireless smart combiner box



Always switch the controller and receiver off when selecting channels.

Hand Controller

Set the required channel number (0 to D) with the channel selector rotary switch. Ensure that the channel is not in use by another device.

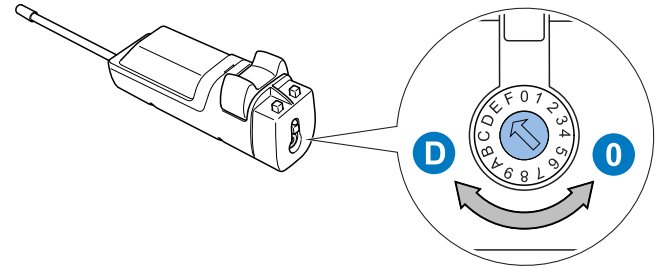

Foot Controller

Set the required channel number (0 to D) with the channel selector rotary switch. Ensure that the channel is not in use by another device.

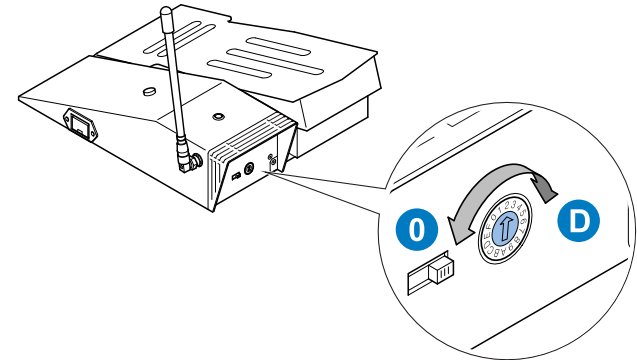

Configuration

Receiver Unit

Set the channel number (0 to D) being used by the specified controller.

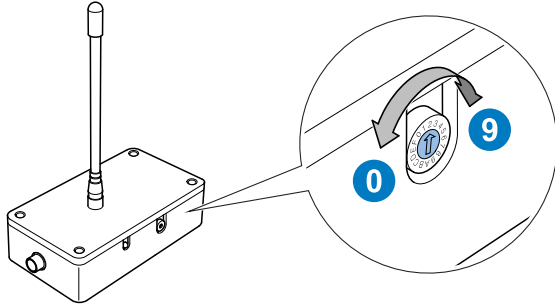

Wireless Smart Combiner Box

A switch is provided on the wireless smart combiner box to select a range of five channels (0 to 4 or 5 to 9) for the unit to receive.

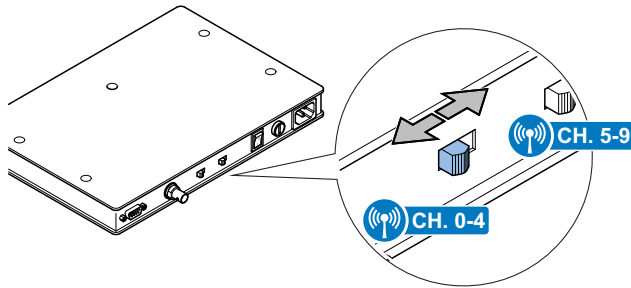

Second Wireless Smart Combiner Box

In an installation with two wireless smart combiner boxes, the second box switch is set to the opposite five channels range.

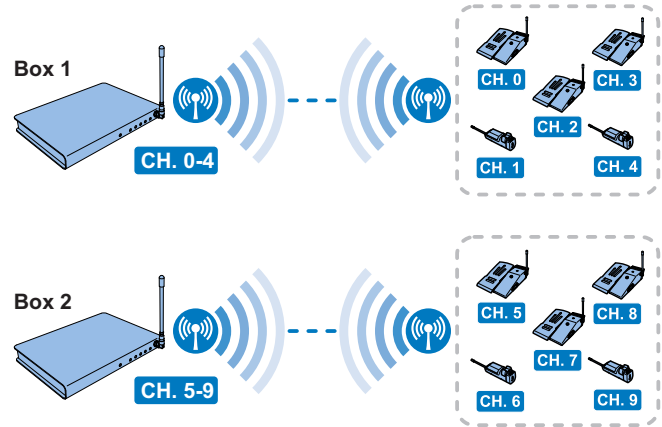

Receiver Indication

The receiver unit and wireless smart combiner box have LEDs to indicate that an active signal is being received from a hand or foot controller. The smart combiner box also indicates which channels are active.

Receiver Unit

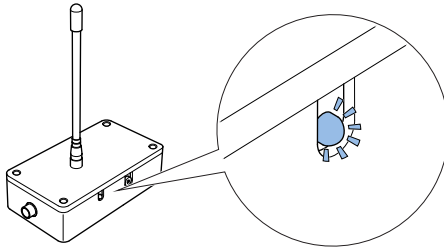

Smart Combiner Box

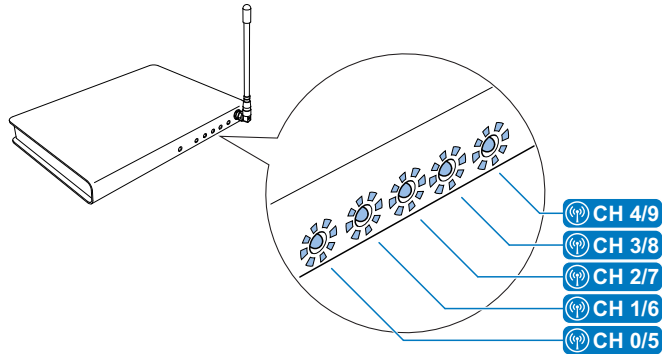

Operation

Using the Hand Controller

The hand controller allows total freedom for the operator to move around a studio and control the speed of the prompted text. The prompted text is controlled using a thumb rocker switch for scroll speed and direction control, with a centre stop. Push buttons are provided for next and previous pages/stories selection.

Prompter Text Control

Scroll Control

The thumb rocker switch is designed to operate with minimal movement. The further the control is moved, the faster the prompter text will scroll. The default actions for the thumb rocker switch is shown below:

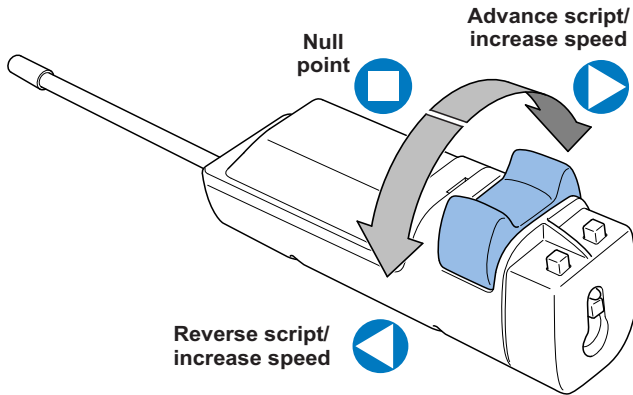

The control will automatically return to a null point between advance and reverse if the unit is not being operated.

Pages and Story Control

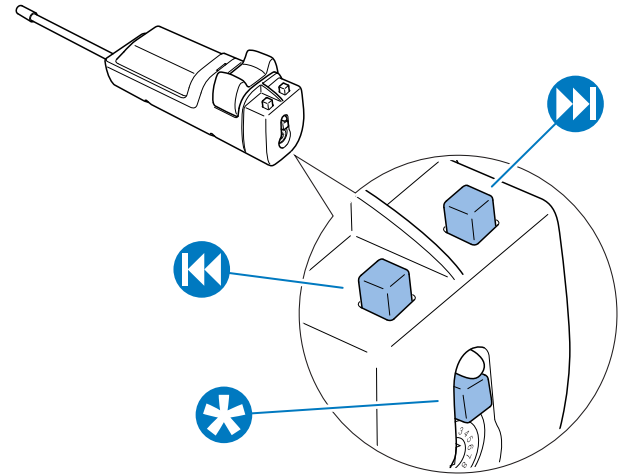

Advances the prompter text forward by one page/ story for each press.



First press - Back to top of the current page/story
Subsequent presses - Back by page/story.



Pressed together - Returns the prompter text to the overall top of the script.



Function button - This can either be programmed through WinPLUS for various functions, or controls devices through a general purpose interface.

Power Save Mode

If the hand controller is idle for more than one minute, it will enter a power save mode to help prolong the life of the battery.

As soon as the thumb rocker switch or a button is used again, the hand controller will resume full operation.

The hand controller only transmits when there is a scroll speed change or a button is pressed.

Low Battery Indicator

When the battery fitted to the hand controller is getting low, the indicator LED flashes to warn the operator, when the controller speed is changed or a button is pressed. The battery should be replaced as soon as possible.

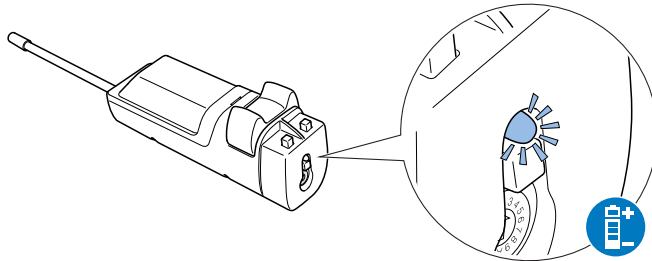

If the hand controller is fitted with a good quality alkaline/ manganese non-rechargeable battery, the estimated remaining operational time from the start of the warning light flashing is 10 hours. For NiMH rechargeable batteries this time is less than 30 minutes.

Lanyard Strap

For security and convenience, a lanyard strap can be fitted to the hand controller.

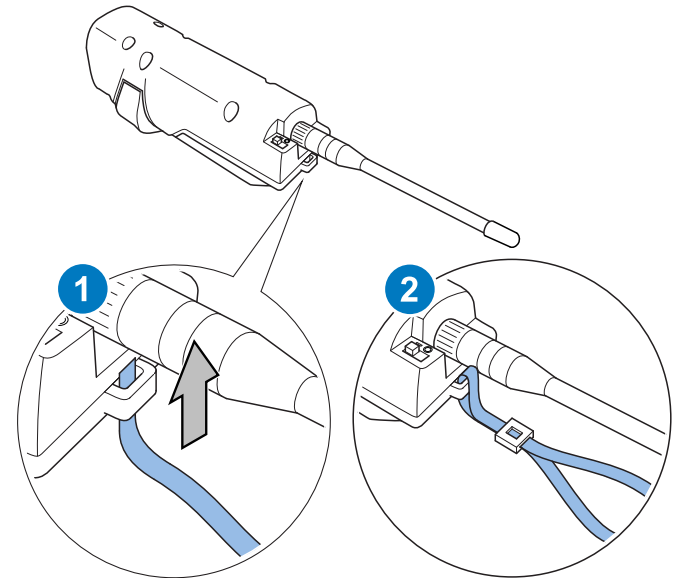

Operation

Using the Foot Controller

The foot controller can be placed in a convenient location on the floor to allow the operator to control the speed of the prompted text discreetly and completely hands free. The prompted text is controlled using a frictionless foot pedal for scroll speed, and a pressure sensitive push button for variable rate reverse speed control.

Prompter Text Forward Control

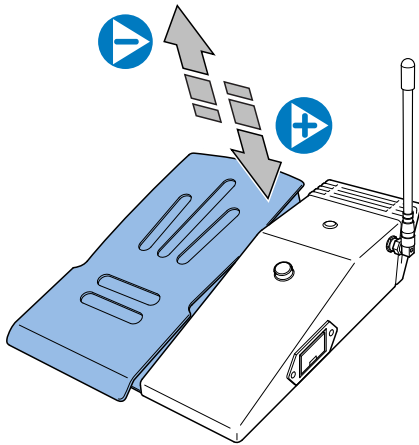

Increase forward scroll speed (depress further).



Decrease forward scroll speed (reduce foot pressure).

Prompter Text Reverse Control

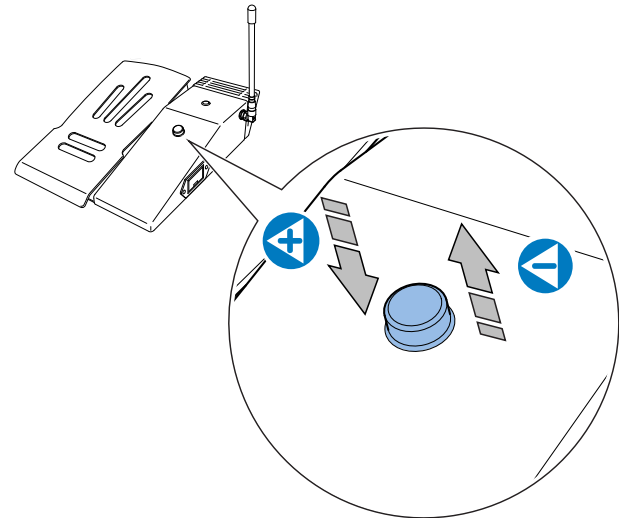

Reverse scroll direction, and increase reverse scroll speed (depress further).



Decrease reverse scroll speed (reduce foot pressure).



When foot pressure is released from either the forwards or reverse foot controls, the script stops scrolling in reverse and remains static.

Low Battery Indicator

When the battery fitted to the foot controller is getting low, the indicator LED flashes to warn the operator, when the foot pedal or reverse button is pressed. The battery should be replaced as soon as possible.

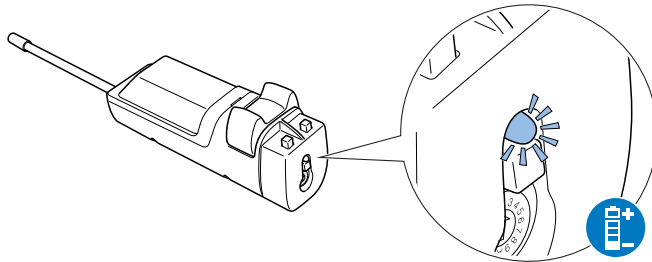

Priority Control

During operation, the control system has built-in intelligence to work on the principle of 'last in takes control'. This means that whichever controller (hand or foot) is currently being operated will take control of the prompted text and override the previous controllers settings.

Maintenance

Routine Maintenance

The wireless products require minimal routine maintenance, apart from checking the connections and overall operation periodically.

Routine checks

During use, check the following:

- Check cables for signs of wear or damage. Replace as necessary.
- Check that all cables are connected properly.

Cleaning



WARNING! Risk of electric shock. Disconnect and isolate the product from the power supply before cleaning.

During normal use the only cleaning required should be a regular wipe over with a dry, lint-free cloth. Dirt accumulated during storage or periods of disuse may be removed with a vacuum cleaner. Particular attention should be paid to all connection ports on the wireless products.

Changing the Fuse (Wireless Smart Combiner Box)



WARNING! Risk of electric shock. Disconnect the power cable. Fuses must only be changed by a trained and competent person.



CAUTION! The replacement fuse must be the correct rating: Type 20mm ceramic tube fuse rated at 1.0 A 250 VAC

1. Switch OFF and disconnect the power cable.
2. Using a flat-blade screwdriver, unscrew and remove the fuse holder and discard the blown fuse.

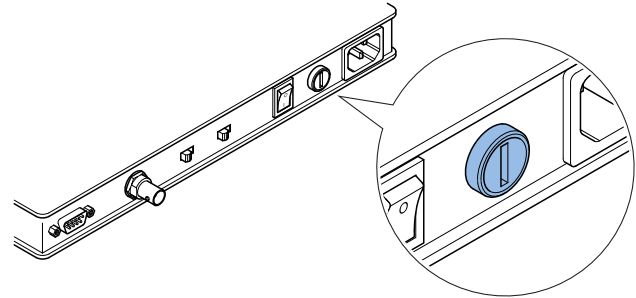

3. Replace the fuse, then reinstall the fuse holder.

Fault	Check	Comments
The receiver unit or smart combiner are not powering up.	Check that the AC or DC power sources are connected and secured.	See the section Power Connections on page 13.
The smart combiner is not powering up.	Check and if necessary replace the fuse.	See the section Changing the Fuse (Wireless Smart Combiner Box) on page 24.
The LED indicator on the hand controller is flashing.	Check that the batteries are working and installed correctly.	See the sections Fitting the Battery - Hand Controller on page 10 or Fitting the Battery - Foot Controller on page 11.
The hand or foot controller are not transmitting and the LED indicators on the receivers are not illuminating.		
The hand or foot controller is transmitting, but not controlling the prompted text.	Check that the channel on the receiver is set to the same channel on the controller.	See the section Channel Frequency Selection on page 17.
	Check that the system connections are correct and secured.	See the sections Control Net Connections on page 12 or Serial Connections on page 13.
	Check that the antennas are fitted and fully secured.	See the section Fitting the Antenna on page 9.
	Check that the controllers are being operated within the permitted reception range.	See the section Receiver Unit or Wireless Smart Combiner Box Location on page 12.
	Another controller is being constantly used by another operator.	See the section Priority Control on page 23.
The hand controller is unresponsive, even after a battery change.	The internal radio module may need to be re-initialised.	See the section Re-initialising the Hand or Foot Controller on page 26.
Wireless transmission and reception is intermittent and unreliable.	Review the wireless installations.	See the section Reliable Wireless Operation on page 26.

Re-initialising the Hand or Foot Controller

In the unlikely event that the hand or foot controller stops transmitting, it may be necessary to re-initialise the internal radio module unit.

1. Switch the controller off and turn the rotary switch to the 'F' position.

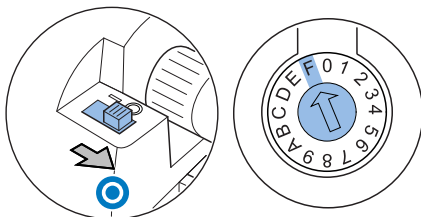

2. Switch the controller on, observing the LED indicator which should flash three times.

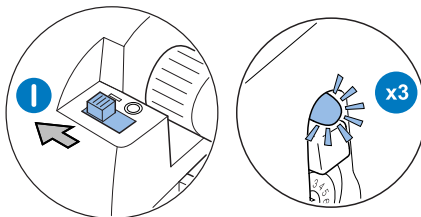

3. Switch the controller off and turn the rotary switch to the desired channel number (0 to D).

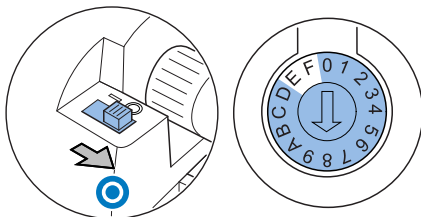

4. Switch the controller on. Full transmitting functionality should be restored.

Reliable Wireless Operation

In the unlikely event that the controllers or receivers are operating intermittently, and it is suspected that wireless connectivity is a problem, the following advice could aid in resolving potential issues.

Physical Obstructions

Reliable wireless reception over any distance relies on a good 'line of sight' contact. Reliable operation is therefore highly dependent on surrounding objects in the studio, and subsequently careful consideration should be given to the controller and receiver antennae positions to minimise obstructions.

Signal Interference

Because the units operate in a license exempt band, there is a possibility that the channel chosen is being used by another nearby device not related to the Autoscript installation. If it is suspected that interference is taking place, the working channel should be changed to avoid such interference. If the interfering device is wide-band, it may be necessary to move the frequency by more than one channel.

For a full list of channel frequencies used on all versions of the wireless products, see the section **Channel Frequencies** on page 27.

Signal Overload

Due to the high sensitivity of the receivers used, it is possible to overload them if the sending device's antenna is used in very close proximity to the receiver's antenna. If this is suspected, either the distance between the receiving and transmitting antennae should be increased, or if this isn't possible, an SMA 10 dB in-line attenuator should be placed between the receiving antenna and the receiver. This is especially relevant if several RF devices are being used in close proximity to one another.

Physical Data

	Hand Controller	Foot Controller	Receiver Unit	Wi-Smart Combiner
Width*	30 mm (1.2 in.)	206 mm (8.1 in.)	60 mm (2.4 in.)	180 mm (7.1 in.)
Length*	110 mm (4.3 in.)	256 mm (10.1 in.)	112 mm (4.4 in.)	260 mm (10.2 in.)
Height*	45 mm (1.8 in.)	73 mm (2.9 in.)	32 mm (1.3 in.)	32 mm (1.2 in.)
Weight	0.15 kg (0.33 lb)	2.35 kg (5.18 lb)	0.122 kg (0.27 lb)	1 kg (2.2 lb)

*Excluding controls, connectors and antennas.

Environmental Data (All Products)

Operating temperature range 5°C to +40°C (41°F to +104°F)

Storage temperature range -20°C to +60°C (-4°F to +140°F)

Electrical Data

	Hand Controller	Foot Controller	Receiver Unit	Smart Combiner
Supply Voltage	9 VDC Battery*	9 VDC Battery*	12 VDC	100-240 VAC
Current (max)	20 mA, (0.2 mA in standby)	25 mA (0.3 mA in standby)	60 mA	0.1 A

* 6LR61/PP3 battery.

Wireless Data

Controller transmission range (max) 100 m (328 ft)

Available channels 14

RF output power (433 MHz) 10 mW

RF output power (900 MHz) 1 mW

Channel Frequencies

Channel Number	Frequency (US)	Frequency (Rest of World)
0	902.3625 MHz	433.1125 MHz
1	902.3875 MHz	433.1375 MHz
2	902.4125 MHz	433.1625 MHz
3	902.4375 MHz	433.1875 MHz
4	902.4625 MHz	433.2125 MHz
5	902.4875 MHz	433.2375 MHz
6	902.5125 MHz	433.2625 MHz
7	902.5375 MHz	433.2875 MHz
8	902.5625 MHz	433.3125 MHz
9	902.5875 MHz	433.3375 MHz
A	902.6125 MHz	433.3625 MHz
B	902.6375 MHz	433.3875 MHz
C	902.6625 MHz	433.4125 MHz
D	902.6875 MHz	433.4375 MHz

Technical Specification

Connections Data

DC Power Socket (Receiver Unit)

Connector type: Hirose DC socket.

Pin	Signal
1	GROUND
4	+12 VDC

Serial Connection (Receiver Unit and Smart Combiner)

Connector type: 9-way D socket.

Pin	Signal
1	TX
5	GROUND
8	RX
9	+12 VDC

Data format is standard RS232 voltage levels, 8 data, 1 stop, no parity, 2400 baud.

Control Net Connection (Receiver Unit and Wireless Smart Combiner)

Connector type: BNC Connector.

Pin	Signal
Tip	Data
Sleeve	Ground

Technical specifications are subject to change without notice.

FCC Certification

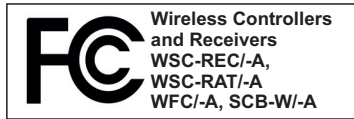

FCC Notice

This product complies with the limits for a Class A digital device, pursuant to Part 15 of the FCC Rules. These limits are designed to provide reasonable protection against harmful interference in a commercial environment. This equipment generates, uses and can radiate radio frequency energy and, if not installed and used in accordance with the instructions, may cause harmful interference with radio communications. Operation of this product in a residential area is likely to cause harmful interference, in which case you will be required to correct the interference at your own expense.

FCC Warning

Changes or modifications not expressly approved by the party responsible for compliance could void the user's authority to operate the equipment.

FCC Declaration of Conformity

This product complies with Part 15 of the FCC Rules. Operation is subject to the following two conditions:

1. This product may not cause harmful interference.
2. This product must accept any interference received, including interference that may cause undesired operations.

Declaration of Conformity



This product complies with the following EU Directives:

- Low Voltage Directive 2006/95/EC
- EMC Directive 2004/108/EC

Compliance with these directives implies conformity to applicable harmonized European standards (European Norms) which are listed on the EU Declaration of Conformity for this product or product family. A copy of the Declaration of Conformity is available upon request.

Environmental considerations

ROHS Compliance Statement

Vitec Videocom Limited is compliant with the European Union Directive 2002/95/EC Restrictions of Hazardous Substances (RoHS) that restricts the use of hazardous substances in Electrical and Electronic Equipment.

General Notices

European Union Waste of Electrical and Electronic Equipment (WEEE) Directive (2002/96/EC)



This symbol marked on the product or its packaging indicates that this product must not be disposed of with general household waste. In some countries or European Community regions separate collection systems have been set up to handle the recycling of electrical and electronic waste products. By ensuring this product is disposed of correctly, you will help prevent potentially negative consequences for the environment and human health. The recycling of materials helps conserve natural resources.

Visit our website for information on how to safely dispose of this product and its packaging.

In countries outside the EU:

Dispose of this product at a collection point for the recycling of electrical and electronic equipment according to your local government regulations.

Pollution statement

This equipment is designed for operation in Pollution Degree 2 environments.

Publication part No. WSC-4980/2

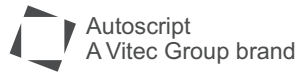

www.autoscript.tv